

a xylem brand

This Datasheet and parts list is for the new style pumps.
 Scroll down for the old style Datasheet.

SELF-PRIMING PUMP

FEATURES

- Body:** Bronze
- Impeller:** Jabsco Neoprene or Nitrile Compound
- Seal:** Lip Type
- Motor:** 115 Volt AC with Replaceable Brushes, Stainless Steel Shaft, 6' cord, three prong grounding plug
- Ports:** 3/8" Internal Pipe Thread
- Height:** 3-5/8"
- Width:** 4"
- Length:** 6-7/8"
- Weight:** 5 lb (2.3 kg)(approx.)

VARIATIONS AVAILABLE

MODEL NO.	DESCRIPTION
12210-0001	Neoprene Impeller
12210-0003	Nitrile (oil resistant) Impeller

APPLICATIONS

INDUSTRIAL: Transferring liquids. Velocity-mixing. Pumping coolants. Pumping waste water to sewer. Cellar, yard and sump drainage. Cooling Heliarc welding equipment.

MARINE: Washing down decks and docks. Water for ship's service supply. Pumping out crank-case oil.

FARMING: Pumping water for stock, poultry houses, farmhouse. Pumping water from wells and cisterns. Pumping liquid ballast into tractor tires. Pumping water from flooded basements.

PLUMBING AND HOME EMERGENCY USE: Pumping out flooded basements, cesspools, sumps, etc. Draining water heaters and water closets. Draining laundry tubs



WARNING
 Explosion hazard. Do not use where flammable vapors are present. To do so can cause an explosion resulting in injury or death.

below sewer level. Removing water trapped between walls, draining inaccessible places when pipes break or leak. Draining fishing ponds and garden pools. Removing sludge, lyewater and other caustics from stopped up drains and sinks.

OPERATING INSTRUCTIONS



1. **INSTALLATION** – Pump may be mounted at any angle without loss of efficiency. Suggested mounting is horizontal or with pump head down. The inlet port is the right hand port when looking at the end cover.
2. **DRIVE** – Direct.
3. **SELF-PRIMING** – Pump will produce a suction lift approaching 5 feet when dry and a lift up to 20 feet when primed. BE SURE SUCTION LINES ARE AIRTIGHT.
4. **RUNNING DRY** – Unit depends on liquid pumped for lubrication. DO NOT RUN DRY for more than 30 seconds. Lack of liquid will damage the impeller.
5. **NOTICE** – Do not pump solvents, thinners, highly concentrated or organic acids. If corrosive fluids must be handled consult Jabsco Chemical Resistance Table (available on request from ITT Jabsco). Pump life will be prolonged if pump is flushed with water after each use or after each work day.
6. **DUTY** – The “Handi-Puppy” is designed for intermittent duty in applications such as: transferring liquids; draining water heaters and water closets; pumping water from basements and other applications which require a few hours of continuous operation.
7. **TEMPERATURES** – Neoprene 45°F (7.2°C) to 180°F (82.2°C), Nitrile 50°F (10°C) to 180°F (82.2°C).
8. **FREEZING WEATHER** – Drain unit by loosening end cover plate.

HEAD CAPACITY TABLE

PSI	FEET	GPM
4.3	10	3.4
8.7	20	3.2
13.0	30	2.9
17.4	40	2.0

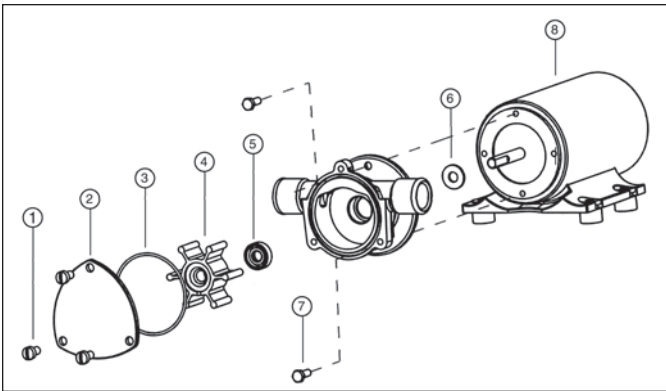

PARTS LIST

KEY	DESCRIPTION	PART NUMBER	QTY.
1	Screw - End Cover	91002-0090	3
2	End Cover	29305-0100	1
3	O-ring (end cover)	92000-0760	1
4	Impeller - Neoprene	1414-0001-P	1
	Impeller - Nitrile	1414-0003-P	1
5	Seal	93000-0100	1
6	Slinger	6342-0000	1
7	Screw (body to motor)	98019-0020	1
8	Motor 12V	9195-0004	1
	Service Kit, Neoprene	90092-0007	
	Service Kit, Nitrile	90092-0004	
	Pump Head only, Neoprene	9040-1001	
	Pump Head only, Nitrile	9040-1003	
	Brush Repair Kit with Caps	42626-0001	

DISASSEMBLY

1. Remove end cover screws, end cover and gasket.
2. Withdraw impeller.

DISASSEMBLY (Cont.)

3. Loosen and remove two slotted hex screws which attach body to motor.
4. Tap body lightly between ports and remove body from motor.
5. Remove seal from body cavity.

NOTE: Do not tamper with or disassemble motor.

ASSEMBLY

1. Lubricate seal. Install in cavity with open side of seal facing impeller.
2. Lubricate motor shaft and install body on motor.
3. Lubricate impeller bore and aligning flat in impeller with flat on motor shaft, install impeller.
4. Install gasket, end cover and screws.

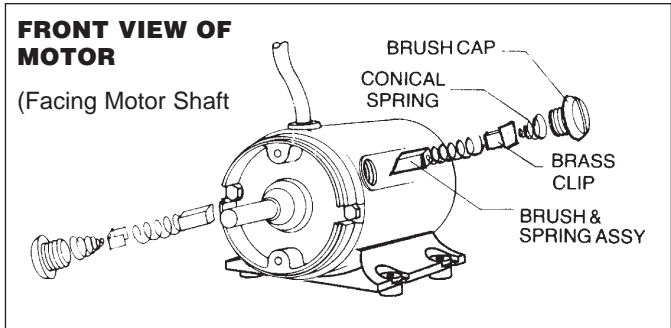

BRUSH REPLACEMENT

Replacement brush kit includes 2 each brush and spring assemblies, brass clips, conical springs, and caps.

Remove old brush assemblies and replace in order shown above. Make sure curvature on end of brush is pointed in direction shown.

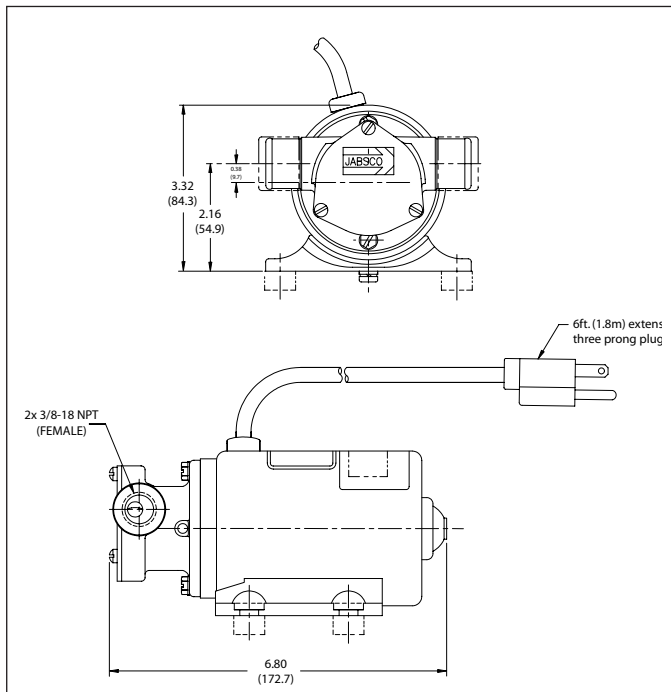

THE PRODUCTS DESCRIBED HEREIN ARE SUBJECT TO THE JABSCO ONE YEAR LIMITED WARRANTY, WHICH IS AVAILABLE FOR YOUR INSPECTION UPON REQUEST.

www.xylemflowcontrol.com



a xylem brand



Model 12210-Series

This Datasheet and parts list is for the old style pumps.
Scroll up for the new style Datasheet.

SELF-PRIMING PUMP

FEATURES

- Body:** Bronze
- Impeller:** Jabsco Neoprene or Nitrile Compound
- Seal:** Lip Type
- Motor:** 115 Volt AC with Replaceable Brushes, Stainless Steel Shaft, 6' cord, three prong grounding plug
- Ports:** 3/8" Internal Pipe Thread and Adaptors for 3/4" garden hose thread
- Height:** 3-5/8"
- Width:** 4"
- Length:** 6-7/8"
- Weight:** 5 lb (2.3 kg)(approx.)

VARIATIONS AVAILABLE

MODEL NO.	DESCRIPTION
12210-0001	Neoprene Impeller
12210-0003	Nitrile (oil resistant) Impeller

APPLICATIONS

INDUSTRIAL: Transferring liquids. Velocity-mixing. Pumping coolants. Pumping waste water to sewer. Cellar, yard and sump drainage. Cooling Heliarc welding equipment.

MARINE: Washing down decks and docks. Water for ship's service supply. Pumping out crank-case oil.

FARMING: Pumping water for stock, poultry houses, farmhouse. Pumping water from wells and cisterns. Pumping liquid ballast into tractor tires. Pumping water from flooded basements.

PLUMBING AND HOME EMERGENCY USE: Pumping out flooded basements, cesspools, sumps, etc. Draining water heaters and water closets. Draining laundry tubs below sewer level. Removing water trapped between walls, draining inaccessible places when pipes break or leak. Draining fishing ponds and garden pools. Removing sludge, lyewater and other caustics from stopped up drains and sinks.

OPERATING INSTRUCTIONS

⚠ WARNING 	Explosion hazard. Do not use where flammable vapors are present. To do so can cause an explosion resulting in injury or death.
---	---

1. **INSTALLATION** – Pump may be mounted at any angle without loss of efficiency. Suggested mounting is horizontal or with pump head down. The inlet port is the right hand port when looking at the end cover.



Model 12210-Series

2. **DRIVE** – Direct.
3. **SELF-PRIMING** – Pump will produce a suction lift approaching 5 feet when dry and a lift up to 20 feet when primed. BE SURE SUCTION LINES ARE AIRTIGHT.
4. **RUNNING DRY** – Unit depends on liquid pumped for lubrication. DO NOT RUN DRY for more than 30 seconds. Lack of liquid will damage the impeller.
5. **NOTICE** – Do not pump solvents, thinners, highly concentrated or organic acids. If corrosive fluids must be handled consult Jabsco Chemical Resistance Table (available on request from ITT Jabsco). Pump life will be prolonged if pump is flushed with water after each use or after each work day.
6. **DUTY** – The “Handi-Puppy” is designed for intermittent duty in applications such as: transferring liquids; draining water heaters and water closets; pumping water from basements and other applications which require a few hours of continuous operation.
7. **TEMPERATURES** – Neoprene 45°F (7.2°C) to 180°F (82.2°C), Nitrile 50°F (10°C) to 180°F (82.2°C).
8. **FREEZING WEATHER** – Drain unit by loosening end cover plate.

HEAD CAPACITY TABLE

PSI	FEET	GPM
4.3	10	3.4
8.7	20	3.2
13.0	30	2.9
17.4	40	2.0

Table shows approximate Head-Flow for new pump in U.S. gallons per minute.

EXPLODED VIEW

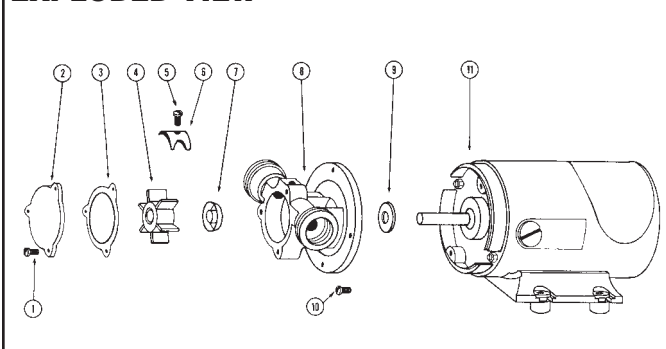

PARTS LIST

KEY	DESCRIPTION	PART NUMBER	QTY.
1	Screw - End Cover (3 per kit)	91002-0090	1
2	End Cover	12076-0000	1
3	Gasket*	7828-0000	1
4	Impeller - Neoprene*	1414-0001	1
	Nitrile	1414-0003	
5	Screw (Cam)	91002-0010	1
6	Cam	8089-0000	1
7	Seal*	93000-0100	1
8	Body	7824-0000	1
9	Slinger	6342-0000	1
10	Screw - Motor (2 per kit)	98019-0020	1
11	Motor and Base Assy.	9195-0004	1
	Replacement Pump Head	9040-0001	
	Neoprene Impeller		
	Replacement Pump Head	9040-0005	
	Nitrile Impeller		
	Service Kit, Neoprene	90092-0007	
	Service Kit, Nitrile	90092-0004	
	†Brush Repair Kit with White Brush Caps	42626-0001	

* Parts contained in Service Kit.

† Brush Kits for motors manufactured prior to 1982 with black brush caps are no longer available.

DISASSEMBLY

1. Remove end cover screws, end cover and gasket.
2. Withdraw impeller.
3. Loosen cam screw and remove cam.*

DISASSEMBLY (Cont.)

4. Loosen and remove two slotted hex screws which attach body to motor.
5. Tap body lightly between ports and remove body from motor.
6. Remove seal from body cavity.

NOTE: Do not tamper with or disassemble motor.

ASSEMBLY

1. Lubricate seal. Install in cavity with open side of seal facing impeller.
2. Lubricate motor shaft and install body on motor.
3. Apply a dab of waterproof sealant to top of cam and reinstall and attach it with cam screw.*
4. Lubricate impeller bore and aligning flat in impeller with flat on motor shaft, install impeller.
5. Install gasket, end cover and screws.

*Cam removal and reinstallation required only when replacing cam.

BRUSH REPLACEMENT

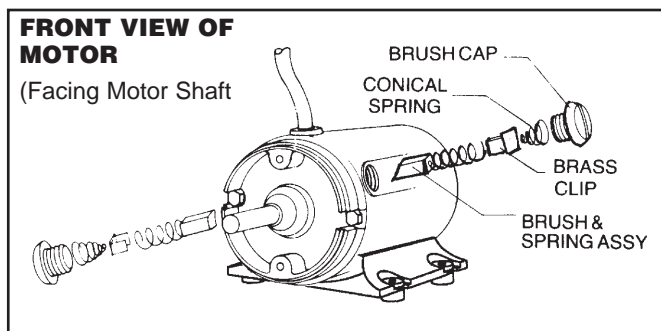

Replacement brush kit includes 2 each brush and spring assemblies, brass clips, conical springs, and caps.

Remove old brush assemblies and replace in order shown above. Make sure curvature on end of brush is pointed in direction shown.

Jabsco



U.S.A.
Jabsco
1485 Dale Way, P.O. Box 2158
Costa Mesa, CA 92628-2158
Tel: (714) 545-8251
Fax: (714) 957-0609

UNITED KINGDOM
Jabsco
Bingley Road, Hoddesdon
Hertfordshire EN11 0BU
Tel: +44 (0) 1992 450145
Fax: +44 (0) 1992 467132

CANADA
Fluid Products Canada
55 Royal Road
Guelph, Ontario N1H 1T1
Tel: (519) 821-1900
Fax: (519) 821-2569

JAPAN
NHK Jabsco Company Ltd.
3-21-10, Shin-Yokohama
Kohoku-Ku, Yokohama, 222
Tel: 045-4758906
Fax: 045-475-8908

GERMANY
Jabsco GmbH
Oststrasse 28
22844 Norderstedt
Tel: +49-40-53 53 73 -0
Fax: +49-40-53 53 73 -11

THE PRODUCTS DESCRIBED HEREIN ARE SUBJECT TO THE JABSCO ONE YEAR LIMITED WARRANTY, WHICH IS AVAILABLE FOR YOUR INSPECTION UPON REQUEST.